

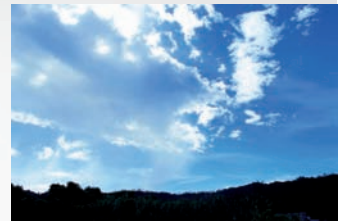

DB-Aire III Systems 50/60Hz

Precision Environmental Control Unit
Cooling Capacity: 3 to 32 TR (10 to 110 kW)



DUNHAM-BUSH[®]

Products that perform...By people who care

DB-AIRE III

Precision Environmental Control Systems

For Technological Room Applications

DB-AIRE III AIR-COOLED DX & CHILLED WATER SYSTEMS

Today's technology rooms require precise, stable environments and design in order for sensitive electronics to operate optimally. Precision air conditioning is designed for close temperature and humidity control. It provides high reliability operation with the ease of service, system flexibility and redundancy necessary to keep the electronic equipments up and running 24 hours a day, 365 days a year.

DB-AIRE III another milestone series offers a wide range of capacities in superior compact, stylish black themed attractive furniture grade cabinets in Upflow/ Downflow configuration to provide room-based cooling, control of perfect humidification and air filtration.

GENERAL INFORMATION

DB-Aire III units are precision environmental control systems that bring a new standard of compact, flexibility and reliable performance to the computer room. Because room requirements differ, DB-Aire III offers a wide range of sizes and styles.

DB-Aire III units (R410A) are ETL listed for North America and Canada regions and certified to AHRI Standard 1360. Optional ETL listed for other regions are available.

DB-AIRE III SYSTEMS

DBAIRE III comes in 2 systems under Air cooled DX and Chilled water system. The nominal capacity range is 3 to 32TR (10 to 110kW) of cooling.

COMPUTER COMFORT

Computer rooms require air which is clean and properly distributed with precisely controlled temperatures and humidity. Building HVAC systems simply are not designed to meet these demands. But, DB-Aire III units easily accomplish these goals with top-rated efficiency, 24 hours per day 7 days a week! DB-Aire III units have been designed to meet the demanding requirements of the most advanced computer room.

Although building HVAC systems cool your staff, they fall short of your computer's comfort need. And they are unable to provide the close humidity control required in a modern data processing centre.

DESIGN FEATURES

- Compact cabinet with anodized aluminum frame, stylish black powder coated panels of 25mm thickness with fiberglass insulation.
- High efficiency VFD scroll compressor (DBA 03-11) in single system and VFD + Fixed speed scroll

compressor (DBA 16-32) in dual system with rotalock connection for ease of service (for Air Cooled DX Systems).

- High-low pressure cutout to protect compressor (for Air Cooled DX Systems).
- Specially built with non screw fixed panels where no special tools required, front access for easier service and maintenance.
- EC fan motor with high efficiency and variable speed modulation.
- Large faced area evaporator coil with hydrophilic fins.
- Deep pleated disposable filter of MERV8 (Ashrae 52.2). Stainless steel finned tabular type electric heater.
- 3-way modulating valve provides accurate temperature control and dehumidification (for Chilled Water Systems).
- Integrated control system within the unit with panel mounting 4.3" graphical color touch screen for temperature/ humidity/alarm control and monitoring.
- Vision 2020i connectivity to BMS for telemonitoring.
- Electronic Expansion Valve (EEV) for efficient capacity modulation and improve performance.
- Hot Gas Reheat for Air Cooled DX systems (optional).
- Supply air plenum box for upflow model.
- Steam generator humidifier (optional).
- Floor water detection alarm (optional).

HIGH PERFORMANCE LOW COST

DB-Aire III designed with a premium features, a lavish outlook and advanced in a technology, neatly formed for a competitive price, makes no room for deniable.

TABLE OF CONTENTS

	Page No
General Information	2
Nomenclature	3
DB-Aire III Monitoring/ Control	4
Network Remote Monitoring (Optional)	7
DB-Aire III Design Features	8
Performance and Technical Data.....	10

	Page No
Dual Coils Option	14
Electrical Data	15
Dimensional & Weight Data	18
Remote Air-Cooled Condensers	19
Guide Specifications	20

DB-AIRE III MONITORING/ CONTROL



VISION 2020i CONTROLLER

The heart of the Environmental Control System is the microprocessor based DB5 controller, a member of Vision 2020i family. The DB5 controller was developed in compliance with the European RoHS directives. The DB5 controller is designed with 32-bit, 44 MHz CPU, 2+2MB built-in flash memory, and built-in clock with battery as standard. The program and the parameters are saved to FLASH-MEMORY and E²PROM, meaning all data is retained even in the event of power failures (without requiring a backup battery). DB5 controller offers various add-on cards which allow supervisory communication to be so easy by just inserting an add-on card into DB5 controller.

DBG5 TOUCH SCREEN DISPLAY

The new DB-AIRE III is equipped with a 4.3" DBG5 color touch screen display as standard display panel. The color touch screen display has graphical resolution of 480 x 272 pixels, 65k colors with LED backlight. This means the display panel will perform high quality images and advanced functions are available for a superior appearance. DBG5 display panel not only monitors your data center's temperature, humidity, airflow, and cleanliness, but also provides component run times, alarm history and an automatic self-test of the microprocessor on system start-up. Multiple messages will be displayed by automatically scrolling from each message to the next. All of these messages are spelled out in English language on the touch screen color display. Multiple alarms will be displayed sequentially in order of occurrence.

OPERATION

DBG5 touch screen panel makes interaction between the user and the unit much easier by simplifying navigation between the various screens. Touch keypad on the DBG5 panel allows unit on/off operation, menu selection, operational information, diagnostics, historical data and trend graph. Multi-level authorization password feature prevents unauthorized access. Another feature is that all menu programmed information for basic system operation and alarm parameters is stored in a non-volatile EEPROM and FLASH-MEMORY where backup battery is not required.

PROGRAMMABLE FUNCTIONS/ MONITORING

The user-friendly touch screen color display permits step-by-step programming and display of the following functions:

- Temperature Set Point 10 to 50°C (50°F- 122°F)
- Temperature Sensitivity 0.5 to 2.7°C (1°F- 5 °F)
- Humidity Set Point (40% - 60% RH)
- Humidity Sensitivity (1% - 10% RH)
- Temperature Alarm Set points
- Humidity Alarm Set points
- Unit Start Time Delay

Normal functions are monitored and displayed on the display panel and include, in addition to the above set points, the following:

- Current Temperature (°C or °F)
- Current Humidity (%RH)
- Cooling Stages 1, 2 as applicable
- Heating Stages 1, 2, 3
- Humidification
- Dehumidification

ALARMS

Alarm conditions are also monitored on the display panel and are enunciated by an audible alarm. The alarm silence button will quiet the audible alarm but the display will continue to indicate the alarm condition until the problem is corrected.

The following alarms are standard:

- Compressor High/Low Pressure
- High and Low Temperature
- High and Low Humidity
- No Airflow
- Filters Blocked
- Humidifier Failure
- Power Failure Restart
- Compressor Short Cycle
- Temperature Sensor Error
- Humidity Sensor Error
- Local Alarm Customer Input Alarm
- Maintenance Due

With add-on optional sensors, the following alarm status can be monitored:

- Under the floor water detection
- No water flows
- Smoke alarm and etc.

In addition, incomparable control settings will be identified on the display panel.

HISTORICAL DATA

In order to facilitate maintenance and service, component run times for fan motor, compressor operation, reheat stages, humidification and dehumidification can be recalled and displayed on the DBG5 display panel. The current temperature and humidity, with the minimum and maximum readings for the last 24 hours of operation, can be recalled and displayed. The last ten alarms and hours since occurrence can also be recalled and displayed. The historical data base is stored in FLASH-MEMORY which does not require backup battery in the event of power failure.

DIAGNOSTICS

Automatic and manual diagnostic sequences simplify troubleshooting.

DB-AIRE III MONITORING/ CONTROL

PROGRAMMING KEY

The programming keys for the Vision 2020i controllers provide easy software updates during both end-of production testing and maintenance procedures.



VISION 2020i COMMUNICATION INTERFACES (Optional)

Below are the available communication interface features of the DB5 controller:

1.) BMS interface

MODBUS RS485 Serial Card

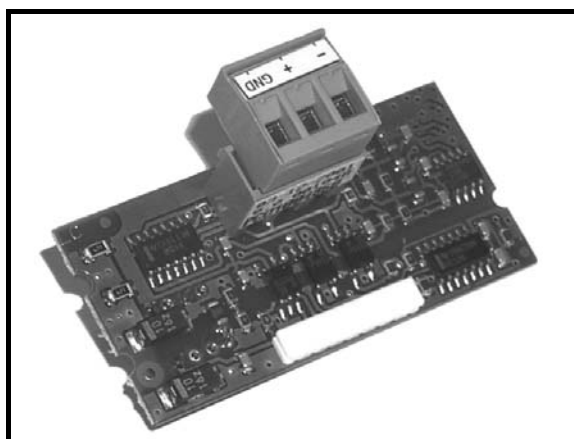

Optional Modbus RS485 add-on card allows Vision 2020i Controller to interface to Modbus Slave, RTU mode, RS485 network. The maximum rate is 19200 and it is set via software.

DB1 LONWORKS FTT10 Card



The optional Lonworks serial card allows Vision 2020i controller to interface to LonWorks® network FTT-10A 78 kbs (TP/FT-10).



2.) BACnet Gateway

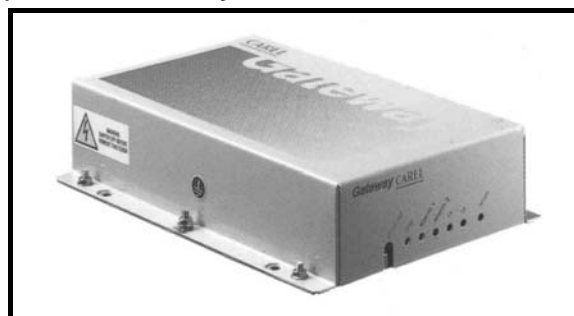

BACnet Gateway allows Vision 2020i controllers (maximum number: 8) to interface with BACnet. This is a frequently used protocol and a property of many BMS manufacturers. This device makes automatically the translation of the Vision 2020i controller transmission protocol into the communication protocol BACnet.

The connections available on the Gateway are:

- Serial 232 (protocol PTP) towards the BACnet;
- Serial 422 or 485 towards Vision 2020i peripherals;
- Serial 232 for the Gateway configuration

3.) WebGate

WebGate is an electronic device to interface all Vision 2020i controllers (maximum 16 units) on a RS485 network to any local 10 Mbps Ethernet network.



Contact the network administrator or other responsible person to arrange a network connection to the WebGate.

The following functions are therefore possible:

- Access information (such as network variables and parameters) from each controller using a standard web browser, such as Internet Explorer™ (version 5 or higher) or NetScape Communicator™ (version 6 or higher) on any PC connected to the WebGate in a local network or WAN. For the better results use a browser supporting CSS style sheets.
- Pass data to a supervising PC connected to the network using the SNMP standard protocol.

DB-AIRE III MONITORING/ CONTROL

Standard Internetworking Protocols: SNMP v1, HTTP, FTP Memory: 128KB RAM, 1MB Flash (400KB available for web pages and user data).

Interfaces: Serial RS485, Serial RS232 DTE interface and Ethernet interface RJ-45 connector.

4.) DB-Web

The optional DB-Web board is used to interface all of the Vision 2020i series controllers to a 10 Mbps Ethernet network and consequently perform the following functions:

- Access the information on the controller (network variables and parameters) using an Internet browser, such as Internet Explorer™ installed on a PC and connected to the DB-Web via TCP/IP.
- Connection to a supervisory network that uses one of the following standard protocols:
 - SNMP v1 & v2c
 - BACnet Ethernet ISO8802-2/8802-3
 - BACnet/IP
- DB-Web is supplied with the DHCP function already active. Therefore, in a network served by a DHCP server, DB-Web will automatically acquire the necessary parameters without requiring configuration, while, in the case of a network without DHCP, the parameters need to be configured manually.

Ethernet interface: RJ45 connector for Ethernet 10BaseT; use a class 5 shielded cable, max 100 meters. Protocols managed: HTTP, FTP, SNMP v1, v2c, DHCP, DNS, BACnet Ethernet ISO8802-2/8802-3, BACnet/IP.

There are two types of interfaces for DB-Web:

ETHERNET interface for:

- BACnet Ethernet
- BACnet over IP
- SNMP v1, v2.c, v3
- HTTP (web server)
- FTP, DHCP,DNS
- Modbus TCP/IP

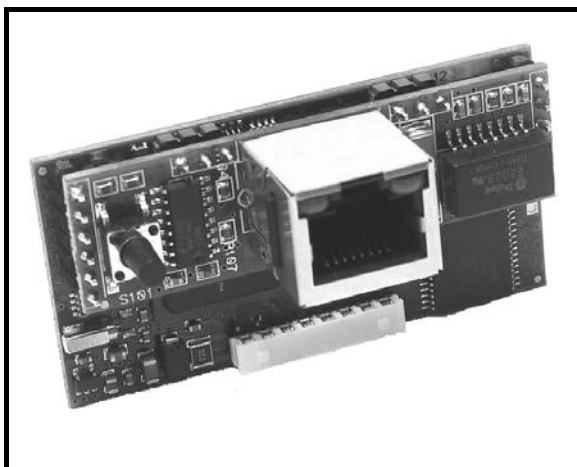

EIA 485 interface for:

- BACnet MS/TP

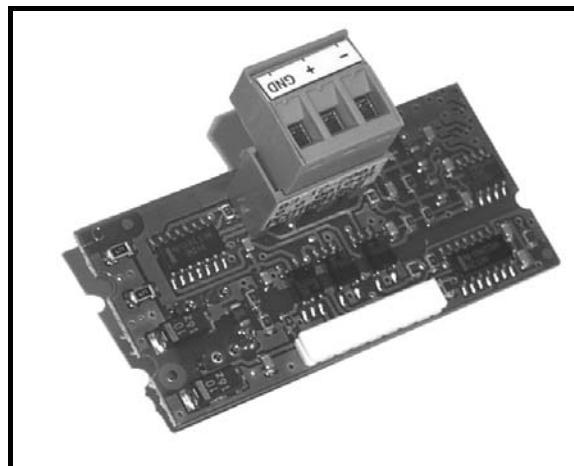

5.) SNMP

SNMP (Simple Network Management Protocol) is a protocol for the management of TCP/IP networks (the Internet protocol), established in 1988 based on the specifications of the IAB (Internet Administration Board), the body that supervises the internet protocol.

All Vision 2020i controllers can be connected Web Gate or DB-Web to a 10 Mbps Ethernet™ network via gateway or DB-web, and communicate with systems that use the SNMP Protocol.

6.) SMS, short message service (with GSM Modem)

Dunham-Bush has pay great attention to fitting the Vision 2020i controllers with the ability to communicate important information directly by SMS message.

In fact, this is the best communication system for sending data wherever and promptly.

By simply connecting a GSM modem, the DB5 controllers not limited to send alarms and information only, but also receive commands via SMS that service personnel can use to reset any alarm or perform the necessary operations, without having to travel to the installation.

NETWORK REMOTE MONITORING (OPTIONAL)

NETWATCH PRO



For smaller systems with the same management and control requirements as larger installations, NetWatchPRO offers the complete and integrated solution for all monitoring and remote management needs.

Complete network and alarm configuration, simple navigation and an attractive design are some of the features that make NetWatchPRO the cutting edge product in its category. A color LCD touch screen, and the use of practical menus, guide the user simply and intuitively, without the use of a PC (however a PC can be connected if necessary), thus providing a practical solution for all those environments that do not have room for a computer.

Other innovative features of NetWatchPRO include:

- Possibility to connect and control up to 100 units DB-AIRE III on RS485 bus;
- Record up to a maximum of 100 variables;
- Log data for up to one year (with 15 min sampling).
- 3 output relays, for alarm signals;
- Possibility to export data (alarms, events, system and model configurations and variable reports) using a USB memory key (the data are downloaded in a format that is compatible with Microsoft® Excel and Microsoft® Word);
- Display graphs;
- Complete alarm configuration;
- Phone book for SMS contacts, fax numbers, e-mail addresses (with optional accessories);
- Possibility for multiple users to access the system, with different privileges (administrator, normal user, user with privileges);
- Instrument suitable for technical environments, no moving parts.

NETVISOR PRO

NetVisor is the Dunham-Bush web-server based monitoring and tele-maintenance system server that features flexibility of use and easy access to information and alarm management functions.

Dunham-Bush has responded to the requirements for local monitoring and remote management by supplying solutions at all levels: from controllers in the field to supervisory systems.

In this way, the user can be constantly kept up-to-date on the status of the installation. Tailor-made tele-maintenance solutions!

The solutions proposed by Dunham-Bush differ according to the type of installation:

- NetVisor PRO Basic, a pc-based solution for local and remote monitoring system. it can monitor up to 90 units of instruments and log 1400 variables. this solution includes a computer system unit but excludes keyboard, mouse and monitor.
- NetVisor PRO Touch Hyper is a complete solution for local and remote monitoring system that can monitor up to 300 units of instruments and log up to 3500 variables. This solution includes a computer system unit with touch screen.
 - 1.) NetVisor PRO can be accessed within a LAN Network, the information from the NetVisor PRO computer can be accessed by other PCs on the same network via Internet Explorer. NetVisor PRO can also be published on the web if a permanent internet connection and static IP is available.
 - 2.) NetVisor PRO has equipped with 2 digital inputs (5V max) and 3 relay (24V max) outputs, the relay contacts can be scheduled to provide control over equipments or in response to alarm or events.

DB-AIRE III DESIGN FEATURES

FRAME AND CABINET



The cabinet comprises an anodized aluminium frame of epoxy powder coated black color paint with nylon corners and removable steel sheet panels. All panels shall be externally installed onto the cabinet by using special stopper system without using screws. The stopper system shall also facilitate the removable of panels for additional ease of field installation, service and maintenance on the system. All panels and access doors shall be fabricated from sturdy heavy gauge of 1.0mm steel sheets with epoxy powder coated oven baked black color paint to provide a durable finish. All panels shall be of 25mm (1 inch) thick single skin and lined with minimum 2lbs/ft³ density thermal and acoustical fiberglass insulation with fire resistant of Class O (BS 476 Part 6, 7). The system shall be designed for front access only with hinged and lock type full height doors.

COOLING COIL

Computer selected coil design, using interwoven coil surface increases unit efficiency at low loads. Air is drawn through the coil at low velocity providing effective surface exposure with minimum turbulence. This provides greater efficiency in the cooling and dehumidification process.

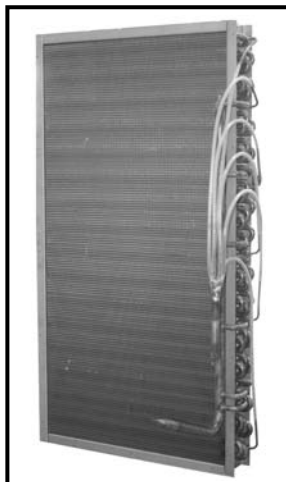

FAN SECTION

The indoor unit are equipped with an electronically commutated (EC) plug fans to make sure the system are driven with 30% lesser energy compare to the conventional AC type. Capability to give higher part load efficiency due to the ability to precisely regulate the airflow according to the load demand makes EC fan is the right choice. The EC fan's impellers were welded with 7 backward curved blades made of aluminium to minimize the bearing load and at the same time maximizing the durability especially when work at high circumferential velocity.

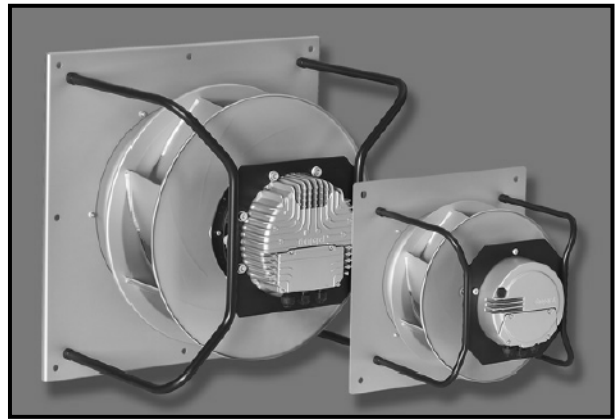

FILTERS

The system shall be provided with 2 inches (50mm) deep (for model 02-05) or 4 inches (100mm) deep (for model 07-26) extended surface pleated disposable type filters rated for MERV8 efficiency to ASHRAE 52.2 standard (equivalent to EU4). Filters shall be withdrawable from the front of the unit.

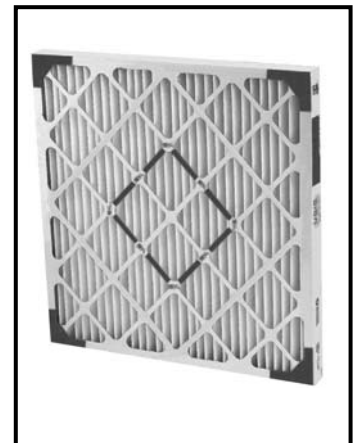

ELECTRICAL REHEAT

The three stages stainless steel finned tubular reheat coils provide ample capacity to maintain room dry bulb conditions during a system call for dehumidification. Three equal stages give a more accurate controlled response to the requirements of the computer room. The heating elements are protected by thermal safety switches. The three stages of reheat create a noticeable lowering of energy use.

DB-AIRE III DESIGN FEATURES

COMPRESSOR



DB-Aire III offers the Variable Frequency Drive (VFD) compressor to satisfy the needs of high efficiency and low energy product. The capability to modulate the compressor speed will allow it to match the on-demand capacity while maintaining the optimum power usage. Significant energy saving can be expected during part load condition. The low start-up frequency is also contributing to the lower initial current peak that usually happen in conventional fix speed compressor.

The DB-Aire III dual compressors model, comes with a combination of one VFD and one fix speed compressor. At low load condition, one compressor will be stop to allow a minimum energy usage.

VFD Advantage 1 – Precisely match the capacity demand thus optimize energy usage.

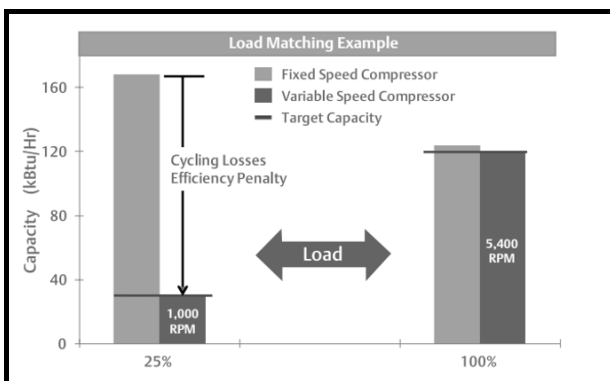

VFD Advantage 2 – Better temperature control compare to normal fix speed control.

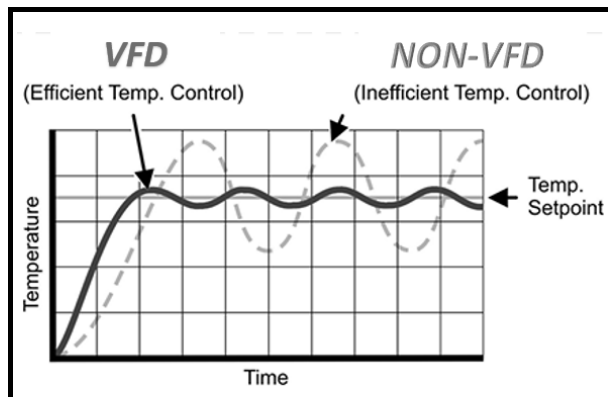

HOT GAS REHEAT (OPTIONAL)

The unit shall incorporate a hot gas reheat coil located downstream of the evaporator coil with modulating valve which is completely integrated to the unit's microprocessor control. For units with two refrigerant circuits, each circuit shall operate independently with its own modulating valve.

HUMIDIFICATION (OPTIONAL)

The disposable cartridge electric steam generator humidifier provides humidification down stream of the cooling coil. The humidifier is designed to allow all units at any voltage to produce full rated steam output at an optimum low water level.

ELECTRONIC EXPANSION VALVE (EEV)

The refrigerant circuit(s) shall be provided with an Electronic Expansion Valve (EEV) for evaporator to allow an efficient modulation control of refrigeration and consistent energy saving performances.

DB-AIRE III HUMID INTERFACE

The DB-Aire III Humid interface allows the control of humidifiers directly from the DB-Aire III microprocessor controller.

AIR COOLED SYSTEMS

A wide range of sizes of remote mounted air-cooled condensers are available from DB-Aire III in vertical discharge. Condensers are manufactured by DB-Aire III and include circuits sized to match the heat rejection of the corresponding compressors. The industrial duty design includes galvanised corrosion resistant housings, high efficiency aluminium finned (optional copper fins available), copper tube coils; coated fan guards, energy efficient thermally protected motors; and integral factory wired and tested control panel.



PERFORMANCE AND TECHNICAL DATA

AIR COOLED DX SYSTEM @ 35°C (95°F) AMBIENT TEMPERATURE - WITH OR WITHOUT HOT GAS REHEAT

MODEL			DBAD/U 03 DBRD/U 03	DBAD/U 05 DBRD/U 05	DBAD/U 09 DBRD/U 09	DBAD/U 11 DBRD/U 11	DBAD/U 14 DBRD/U 14	DBAD/U 16 DBRD/U 16	DBAD/U 19 DBRD/U 19	DBAD/U 22 DBRD/U 22	DBAD/U 26 DBRD/U 26	DBAD/U 29 DBRD/U 29	DBAD/U 32 DBRD/U 32	
Return Air 75F/62.5F/50% RH (24C/17C/50% RH)	Total Cooling Capacity	MBH (kW)	35.8 (10.5)	55.5 (16.3)	107.4 (31.5)	128.3 (37.6)	167.1 (49.0)	202.1 (59.2)	229.9 (67.4)	261.8 (76.7)	306.5 (89.8)	345.8 (101.3)	377.5 (110.6)	
	Sensible Cooling Capacity	MBH (kW)	33.0 (9.7)	51.6 (15.1)	102.3 (30.0)	121.1 (35.5)	148.5 (43.5)	178.3 (52.3)	219.4 (64.3)	233.7 (68.5)	268.6 (78.7)	314.2 (92.1)	354.4 (103.9)	
	Sensible Heat Ratio (SHR)		0.92	0.93	0.95	0.94	0.89	0.88	0.95	0.89	0.88	0.91	0.94	
Return Air 72F/60F/50% RH (22C/16C/50% RH)	Total Cooling Capacity	MBH (kW)	35.9 (10.5)	55.3 (16.2)	108.1 (31.7)	119.6 (35.1)	164.4 (48.2)	188.2 (55.2)	227.9 (66.8)	243.9 (71.5)	286.2 (83.9)	335.7 (98.4)	353.5 (103.6)	
	Sensible Cooling Capacity	MBH (kW)	33.2 (9.7)	51.2 (15.0)	101.5 (29.8)	109.9 (32.2)	139.5 (40.9)	171.6 (50.3)	218.0 (63.9)	224.9 (65.9)	262.6 (77.0)	294.1 (86.2)	346.6 (101.6)	
	Sensible Heat Ratio (SHR)		0.92	0.93	0.94	0.92	0.85	0.91	0.96	0.92	0.92	0.88	0.98	
Return Air 75F/52F Dew Point (24C/11C Dew Point)	Total Cooling Capacity	MBH (kW)	34.6 (10.1)	54.0 (15.8)	104.4 (30.6)	117.5 (34.4)	167.4 (49.1)	180.7 (53.0)	221.5 (64.9)	234.3 (68.7)	275.2 (80.7)	341.4 (100.1)	346.6 (101.6)	
Class 1 AHRI 1360 rating condition	Sensible Cooling Capacity	MBH (kW)	33.4 (9.8)	52.3 (15.3)	102.4 (30.0)	117.5 (34.4)	150.6 (44.1)	175.1 (51.3)	221.5 (64.9)	226.6 (66.4)	264.3 (77.5)	318.4 (93.3)	346.6 (101.6)	
COMPRESSOR VFD Compressor (Single) VFD + Fix Compressor (Dual)	Number of Compressor(s)		1	1	1	1	2	2	2	2	2	2	2	
	Total Power Input (50Hz)	kW	2.4	4.1	8.6	9.0	13.9	14.6	18.7	18.2	23.4	30.0	28.1	
	Total Power Input (60Hz)	kW	2.6	4.3	8.8	9.2	14.1	15.4	19.2	19.1	24.4	31.0	28.0	
	Hot Gas; Liquid Lines, 50Hz	In	1/2 ; 3/8	1/2 ; 3/8	7/8 ; 5/8	7/8 ; 5/8	7/8 ; 5/8	7/8(2) ; 5/8(2)	7/8(2) ; 5/8(2)	7/8(2) ; 5/8(2)	7/8(2) ; 5/8(2)	7/8(2) ; 5/8(2)	7/8(2) ; 5/8(2)	7/8(2) ; 5/8(2)
	Hot Gas; Liquid Lines, 60Hz	In	1/2 ; 3/8	1/2 ; 3/8	7/8 ; 5/8	7/8 ; 5/8	7/8 ; 5/8	7/8(2) ; 5/8(2)	7/8(2) ; 5/8(2)	7/8(2) ; 5/8(2)	7/8(2) ; 5/8(2)	7/8(2) ; 5/8(2)	7/8(2) ; 5/8(2)	7/8(2) ; 5/8(2)
EC FAN (INDOOR)	Fan Qty		1	1	1	2	2	2	2	2	3	3	3	
	Air Volume	CFM (m ³ /h)	1,500 (2,548)	2,500 (4,247)	5,000 (8,495)	6,000 (10,194)	8,000 (13,592)	10,000 (16,989)	11,000 (18,688)	11,000 (18,688)	13,000 (22,086)	15,000 (25,485)	18,000 (30,582)	
	ESP	in H ₂ O (Pa)	1.5 (374)	1.5 (374)	1.5 (374)	1.5 (374)	1.5 (374)	1.5 (374)	1.5 (374)	1.5 (374)	1.5 (374)	1.5 (374)	1.5 (374)	
	Fan Size OD	mm	355	355	500	355	355	500	500	500	500	500	500	
COIL (DX)	Face Area	ft ² (m ²)	5.6 (0.5)	5.6 (0.5)	12.2 (1.1)	12.2 (1.1)	23.9 (2.2)	23.9 (2.2)	23.9 (2.2)	23.9 (2.2)	23.9 (2.2)	33.1 (3.1)	33.1 (3.1)	
	Face Velocity	FPM (m/s)	270 (1.4)	450 (2.3)	409 (2.1)	491 (2.5)	335 (1.7)	419 (2.1)	461 (2.3)	461 (2.3)	544 (2.8)	453 (2.2)	544 (2.8)	
	Condensate Drain O.D	In	7/8	7/8	7/8	7/8	7/8	7/8	7/8	7/8	7/8	7/8	7/8	
FILTERS (ASHRAE 52.5 MERV 8)	20" x 20" x 2"	Qty	2	2	N/A	N/A	N/A	N/A	N/A	N/A	N/A	N/A	N/A	
	20" x 20" x 4"	Qty	N/A	N/A	4	4	6	6	6	6	6	4	4	
	20" x 25" x 4"	Qty	N/A	N/A	N/A	N/A	2	2	2	2	2	6	6	
REHEAT (Electric)	3-Stages (rated at 415V)	MBH (kW)	20.5 (6.0)	20.5 (6.0)	41.0 (12.0)	41.0 (12.0)	61.4 (18.0)	61.4 (18.0)	61.4 (18.0)	61.4 (18.0)	61.4 (18.0)	61.4 (18.0)	61.4 (18.0)	
STEAM HUMIDIFIER (OPTIONAL)	Capacity (max.)	lbs/hr (kg/hr)	17 (8.0)	17 (8.0)	17 (8.0)	17 (8.0)	33 (15.0)	33 (15.0)	33 (15.0)	33 (15.0)	33 (15.0)	33 (15.0)	33 (15.0)	
	Power Input (max.)	kW	6.0	6.0	6.0	6.0	11.3	11.3	11.3	11.3	11.3	11.3	11.3	
SOUND PRESSURE LEVEL (at 2m distance, free field, downflow)		dBA	61	57	60	62	65	68	73	74	70	70	72	



PERFORMANCE AND TECHNICAL DATA

CHILLED WATER SYSTEM @ WATER SUPPLY/ RETURN 7°C/ 12°C (44.6°F/ 53.6°F)

Model			DBC/D/U 03	DBC/D/U 05	DBC/D/U 09	DBC/D/U 11	DBC/D/U 14	DBC/D/U 16	DBC/D/U 19	DBC/D/U 22	DBC/D/U 26	DBC/D/U 29	DBC/D/U 32	
Return Air 75F/62.5F/50% RH (24C/17C/50% RH)	Total Cooling Capacity	MBH (kW)	43.0 (12.6)	67.9 (19.9)	132.3 (38.8)	162.0 (47.5)	205.3 (60.2)	240.5 (70.5)	280.9 (82.3)	319.0 (93.5)	360.4 (105.6)	444.1 (130.2)	507.4 (148.7)	
	Sensible Cooling Capacity	MBH (kW)	37.1 (10.9)	61.0 (17.9)	118.6 (34.8)	145.3 (42.6)	184.9 (54.2)	221.9 (65.0)	255.5 (74.9)	277.1 (81.2)	318.1 (93.2)	385.7 (113.1)	448.3 (131.4)	
	Sensible Heat Ratio (SHR)		0.86	0.90	0.90	0.90	0.90	0.92	0.91	0.87	0.88	0.87	0.88	
	Water Flow Rate	GPM (m ³ /hr)	9.9 (2.2)	15.6 (3.5)	29.7 (6.7)	37.2 (8.4)	47.1 (10.7)	55.1 (12.5)	64.4 (14.6)	73.2 (16.6)	82.7 (18.8)	98.8 (22.4)	112.9 (25.6)	
	Water Pressure Drop	PSI (kPa)	5.5 (38.0)	2.7 (18.8)	10.1 (69.6)	4.1 (28.4)	2.3 (15.5)	3.0 (20.6)	2.7 (18.5)	6.5 (45.1)	8.1 (55.6)	6.9 (47.5)	8.7 (60.1)	
Return Air 80°F/66.6°F/ 50% RH (26.6°C/19.2°C/ 50% RH)	Total Cooling Capacity	MBH (kW)	64.1 (18.8)	98.8 (29.0)	188.4 (55.2)	235.2 (68.9)	300.5 (88.1)	351.2 (102.9)	409.2 (119.9)	461.3 (135.2)	520.7 (152.6)	602.1 (176.5)	687.4 (201.5)	
	Sensible Cooling Capacity	MBH (kW)	42.9 (12.6)	69.0 (20.2)	130.8 (38.3)	164.7 (48.3)	210.5 (61.7)	251.3 (73.7)	289.2 (84.8)	314.6 (92.2)	360.0 (105.5)	423.5 (124.1)	490.8 (143.8)	
	Sensible Heat Ratio (SHR)		0.67	0.70	0.69	0.70	0.70	0.72	0.71	0.68	0.69	0.70	0.71	
	Water Flow Rate	GPM (m ³ /hr)	14.3 (3.2)	22.0 (5.0)	41.9 (9.5)	52.3 (11.9)	66.8 (15.2)	78.1 (17.7)	91 (20.7)	102.6 (23.3)	115.8 (26.3)	134.0 (30.4)	152.9 (34.7)	
	Water Pressure Drop	PSI (kPa)	10.4 (71.4)	4.9 (34.1)	18.3 (125.8)	7.5 (51.7)	4.2 (28.7)	5.5 (37.7)	4.9 (34.1)	11.7 (81.0)	14.5 (99.8)	11.8 (81.3)	14.9 (102.8)	
EC FAN (INDOOR)	Fan Qty		1	1	1	2	2	2	2	2	3	3	4	
	Air Volume	CFM (m ³ /h)	1,500 (2,548)	2,500 (4,247)	5,000 (8,495)	6,000 (10,194)	8,000 (13,592)	10,000 (16,989)	11,000 (18,688)	11,000 (18,688)	13,000 (22,086)	15,000 (25,485)	18,000 (30,582)	
	External Static Pressure (ESP)	in H ₂ O (Pa)	1.5 (374)	1.5 (374)	1.5 (374)	1.5 (374)	1.5 (374)	1.5 (374)	1.5 (374)	1.5 (374)	1.5 (374)	1.5 (374)	1.5 (374)	
	Fan Size OD	mm	355	355	500	355	355	500	500	500	500	500	500	
Coil (Chilled Water)	Face Area	ft ² (m ²)	5.6 (0.5)	5.6 (0.5)	12.2 (1.1)	12.2 (1.1)	23.9 (2.2)	23.9 (2.2)	23.9 (2.2)	23.9 (2.2)	23.9 (2.2)	33.1 (3.1)	33.1 (3.1)	
	Face Velocity	FPM (m/s)	270 (1.4)	450 (2.3)	409 (2.1)	491 (2.5)	335 (1.7)	419 (2.1)	461 (2.3)	461 (2.3)	544 (2.8)	453 (2.2)	544 (2.8)	
	Condensate Drain O.D	Inch	7/8	7/8	7/8	7/8	7/8	7/8	7/8	7/8	7/8	7/8	7/8	
Chilled Water Control	3-Way Modulating Valve, Size	DN, mm	25	25	25	40	40	40	40	40	50	50	50	
		Kv, m ³ /h	10	10	10	16	16	16	16	16	25	25	25	
Filters (ASHRAE 52.5 MERV 8)	20" x 20" x 2"	Qty	2	2	N/A	N/A	N/A	N/A	N/A	N/A	N/A	N/A	N/A	
	20" x 20" x 4"	Qty	N/A	N/A	4	4	6	6	6	6	6	4	4	
	20" x 25" x 4"	Qty	N/A	N/A	N/A	N/A	2	2	2	2	2	6	6	
Reheat (Electric)	3-Stages (rated at 415V)	MBH (kW)	20.5 (6.0)	20.5 (6.0)	41.0 (12.0)	41.0 (12.0)	61.4 (18.0)	61.4 (18.0)	61.4 (18.0)	61.4 (18.0)	61.4 (18.0)	61.4 (18.0)	61.4 (18.0)	
Steam Humidifier (Optional)	Capacity (max.)	lbs/hr (kg/hr)	17 (8.0)	17 (8.0)	17 (8.0)	17 (8.0)	33 (15.0)	33 (15.0)	33 (15.0)	33 (15.0)	33 (15.0)	33 (15.0)	33 (15.0)	
	Power Input (max.)	kW	6.0	6.0	6.0	6.0	11.3	11.3	11.3	11.3	11.3	11.3	11.3	
Sound Pressure Level (at 2m distance, free field, downflow)			dBA	41	54	60	62	65	68	77	77	69	70	72

DUAL COILS OPTION

AIR COOLED DX & CHILLED WATER SYSTEMS

This system is a combination of the both Direct Expansion (DX) and Chilled Water (CW) system with 2 cooling coil. Cooling capacity and other parameters for DX and CW System are as per stated on respective tables; except for the following.

Model	DBDD/U 03	DBDD/U 05	DBDD/U 09	DBDD/U 11	DBDD/U 14	DBDD/U 16
Sound Pressure Level (at 2m distance, free field, downflow)	dBA 61	58	63	65	70	70

Model	DBDD/U 19	DBDD/U 22	DBDD/U 26	DBDD/U 29	DBDD/U 32
Sound Pressure Level (at 2m distance, free field, downflow)	dBA 81	81	75	75	76

CONDENSER SELECTION

Selections are to be based on standard airflow rate and return air temperature of 24°C / 17°C (75°F / 62.5°F) or lesser at sea level.

Model	DX-System	DBAD/U 03	DBAD/U 05	DBAD/U 09	DBAD/U 11	DBAD/U 14	DBAD/U 16
	Dual Coils System	DBDD/U 03	DBDD/U 05	DBDD/U 09	DBDD/U 11	DBDD/U 14	DBDD/U 16
	DX-System with Hot Gas Reheat	DBRD/U 03	DBRD/U 05	DBRD/U 09	DBRD/U 11	DBRD/U 14	DBRD/U 16
Total Heat Rejection (Nominal)	MBH (kW)	46 (14)	73 (21)	151 (44)	171 (50)	220 (64)	262 (77)
35°C (95°F) Ambient	-	DBRC04	DBRC06	DBRC10	DBRC13	DBRC17	DBRC20
37.8°C (100°F) Ambient	-	DBRC04	DBRC06	DBRC13	DBRC17	DBRC20	DBRC26
40.6°C (105°F) Ambient	-	DBRC06	DBRC08	DBRC17	DBRC20	DBRC26	DBRC26
43°C (110°F) Ambient	See Note 1	DBRC06	DBRC11	DBRC20	DBRC26	DBRC34	DBRC40
46°C (115°F) Ambient	See Note 1	DBRC11	DBRC17	DBRC34	DBRC40	DBRC44	DBRC30 x 2
49°C (120°F) Ambient	See Note 2	DBRC11	DBRC20	DBRC34	DBRC40	DBRC44	DBRC30 x 2
52°C (125°F) Ambient	See Note 3	DBRC13	DBRC26	DBRC40	DBRC44	DBRC26 x 2	DBRC30 x 2

Model	DX-System	DBAD/U 19	DBAD/U 22	DBAD/U 26	DBAD/U 29	DBAD/U 32
	Dual Coils System	DBDD/U 19	DBDD/U 22	DBDD/U 26	DBDD/U 29	DBDD/U 32
	DX-System with Hot Gas Reheat	DBRD/U 19	DBRD/U 22	DBRD/U 26	DBRD/U 29	DBRD/U 32
Total Heat Rejection (Nominal)	MBH (kW)	293 (86)	332 (97)	388 (114)	445 (130)	465 (136)
35°C (95°F) Ambient	-	DBRC20	DBRC26	DBRC30	DBRC34	DBRC34
37.8°C (100°F) Ambient	-	DBRC26	DBRC30	DBRC30	DBRC40	DBRC40
40.6°C (105°F) Ambient	-	DBRC34	DBRC34	DBRC34	DBRC44	DBRC44
43°C (110°F) Ambient	See Note 1	DBRC44	DBRC44	DBRC44	DBRC40 x 2	DBRC40 x 2
46°C (115°F) Ambient	See Note 1	DBRC30 x 2	DBRC40 x 2	DBRC40 x 2	DBRC40 x 2	DBRC40 x 2
49°C (120°F) Ambient	See Note 2	DBRC34 x 2	DBRC40 x 2	DBRC44 x 2	DBRC44 x 2	DBRC44 x 2
52°C (125°F) Ambient	See Note 3	DBRC34 x 2	DBRC44 x 2	DBRC44 x 2	DBRC44 x 2	DBRC44 x 2

Notes: 1.) Multiply Total Compressor Power Input by 1.05
 2.) Multiply Cooling Capacity by 0.9. Multiply Total Compressor Power Input by 1.1
 3.) Multiply Cooling Capacity by 0.9. Multiply Total Compressor Power Input by 1.2

ELECTRICAL DATA

AIR COOLED DX & CHILLED WATER SYSTEMS

1.) STANDARD - COOLING & ELECTRIC HEATERS

At 35°C (95°F) ambient; Return Air at 24°C/17°C/50 %RH (75°F/62.5°F/50 %RH)

Model	DBAD/U 03			DBAD/U 05			DBAD/U 09			DBAD/U 11			DBAD/U 14			DBAD/U 16		
	RLA	MCA	MFS	RLA	MCA	MFS	RLA	MCA	MFS	RLA	MCA	MFS	RLA	MCA	MFS	RLA	MCA	MFS
380-415V/ 3Ph/ 50Hz	13.8	15	20	17.1	19	25	32.5	35.1	50	39.1	43	60	59.2	62	80	60.8	65	80
380V/ 3Ph/ 60Hz	13.8	15	20	17.1	19	25	32.5	35	50	39.1	43	60	59.1	62	80	61.2	66	80
460V/ 3Ph/ 60Hz	12.3	13	20	15.6	17	25	29.3	32	45	35.9	40	60	53.7	56	70	54.9	59	80

Model	DBAD/U 19			DBAD/U 22			DBAD/U 26			DBAD/U 29			DBAD/U 32		
	RLA	MCA	MFS	RLA	MCA	MFS	RLA	MCA	MFS	RLA	MCA	MFS	RLA	MCA	MFS
380-415V/ 3Ph/ 50Hz	66.4	70	90	71.1	76	100	75.1	81	125	89.5	97	150	103.8	111	150
380V/ 3Ph/ 60Hz	64.9	69	80	73.5	79	100	78.5	85	110	94.0	102	150	103	111	150
460V/ 3Ph/ 60Hz	58.8	63	80	67	72	100	72	78	110	81.1	88	125	93.6	101	150

Return Air at 24°C/17°C/50 %RH (75°F/62.5°F/50 %RH)

Model	DBCD/U 03			DBCD/U 05			DBCD/U 09			DBCD/U 11			DBCD/U 14			DBCD/U 16		
	RLA	MCA	MFS	RLA	MCA	MFS	RLA	MCA	MFS	RLA	MCA	MFS	RLA	MCA	MFS	RLA	MCA	MFS
380-415V/ 3Ph/ 50Hz	10.1	10	15	11.2	12	15	22.1	23	30	23.1	24	30	34.8	37	45	33.7	35	45
380V/ 3Ph/ 60Hz	10.1	10	15	11.2	12	15	22.1	23	30	23.1	24	30	34.8	37	45	33.7	35	40
460V/ 3Ph/ 60Hz	8.5	9	15	9.7	10	15	22.1	23	30	20	21	30	34.8	37	45	29	31	40

Model	DBCD/U 19			DBCD/U 22			DBCD/U 26			DBCD/U 29			DBCD/U 32		
	RLA	MCA	MFS	RLA	MCA	MFS	RLA	MCA	MFS	RLA	MCA	MFS	RLA	MCA	MFS
380-415V/ 3Ph/ 50Hz	36.0	38	50	36.3	39	50	37.3	40	50	41.8	53	70	49.8	53	70
380V/ 3Ph/ 60Hz	36.0	38	45	36.3	39	45	37.3	40	45	41.8	45	60	49.8	53	60
460V/ 3Ph/ 60Hz	31.3	34	45	31.5	34	45	32.6	35	45	41.8	45	60	43.4	47	60

2.) STANDARD WITH OPTIONAL HUMIDIFIER

At 35°C (95°F) ambient; Return Air at 24°C/ 17°C/50 %RH (75°F/62.5°F/50 %RH)

Model	DBAD/U 03			DBAD/U 05			DBAD/U 09			DBAD/U 11			DBAD/U 14			DBAD/U 16		
	RLA	MCA	MFS	RLA	MCA	MFS	RLA	MCA	MFS	RLA	MCA	MFS	RLA	MCA	MFS	RLA	MCA	MFS
380-415V/ 3Ph/ 50Hz	23.0	24	30	26.3	28	35	41.6	44	60	48.2	52	70	76.4	79	90	78.0	82	100
380V/ 3Ph/ 60Hz	23.0	24	25	26.3	28	35	41.6	44	60	48.2	52	70	76.3	79	90	78.4	83	100
460V/ 3Ph/ 60Hz	19.8	21	25	23.1	25	35	36.9	40	50	43.4	47	70	67.9	71	90	69.1	73	100

Model	DBAD/U 19			DBAD/U 22			DBAD/U 26			DBAD/U 29			DBAD/U 32		
	RLA	MCA	MFS	RLA	MCA	MFS	RLA	MCA	MFS	RLA	MCA	MFS	RLA	MCA	MFS
380-415V/ 3Ph/ 50Hz	83.6	88	110	88.2	93	110	92.2	98	150	106.7	114	150	121.0	128	175
380V/ 3Ph/ 60Hz	82.1	86	100	90.7	96	110	95.6	102	125	111.1	120	150	120.2	128	150
460V/ 3Ph/ 60Hz	73.0	77	100	81.2	87	110	86.2	92	125	95.3	102	150	107.8	116	150

Note : RLA - Rated Load Amps

MCA - Minimum Circuit Amps

MFS - Maximum Fuse Size

Return Air at 24°C/17°C/50 %RH (75°F/62.5°F/50 %RH)

Model	DBCD/U 03			DBCD/U 05			DBCD/U 09			DBCD/U 11			DBCD/U 14			DBCD/U 16		
	RLA	MCA	MFS	RLA	MCA	MFS	RLA	MCA	MFS	RLA	MCA	MFS	RLA	MCA	MFS	RLA	MCA	MFS
380-415V/ 3Ph/ 50Hz	19.2	19	20	20.4	21	25	31.2	32	40	32.2	33	40	52.0	54	70	50.9	52	60
380V/ 3Ph/ 60Hz	19.2	19	20	20.4	21	20	31.2	32	40	32.2	34	35	52.0	54	70	50.9	53	60
460V/ 3Ph/ 60Hz	16.0	16	20	17.2	18	20	29.6	31	35	27.5	29	35	49.0	51	60	43.1	45	60

Model	DBCD/U 19			DBCD/U 22			DBCD/U 26			DBCD/U 29			DBCD/U 32		
	RLA	MCA	MFS	RLA	MCA	MFS	RLA	MCA	MFS	RLA	MCA	MFS	RLA	MCA	MFS
380-415V/ 3Ph/ 50Hz	53.2	55	70	53.5	56	70	54.5	57	70	59.0	63	80	67.0	70	90
380V/ 3Ph/ 60Hz	53.2	55	60	53.5	56	60	54.5	57	60	59.0	63	80	67.0	70	80
460V/ 3Ph/ 60Hz	45.5	48	60	45.7	48	60	46.8	49	60	56.0	60	80	57.6	61	80

ELECTRICAL DATA

AIR COOLED DUAL COILS (DX + CW) & DX WITH HOT GAS REHEAT SYSTEMS

1.) STANDARD - COOLING & ELECTRIC HEATERS

At 35°C (95°F) ambient; Return Air at 24°C/17°C/50 %RH (75°F/62.5°F/ 50 %RH)

Model	DBDD/U 03				DBDD/U 05				DBDD/U 09				DBDD/U 11				DBDD/U 14				DBDD/U 16			
	RLA (DX)	RLA (CHW)	MCA	MFS	RLA (DX)	RLA (CHW)	MCA	MFS	RLA (DX)	RLA (CHW)	MCA	MFS	RLA (DX)	RLA (CHW)	MCA	MFS	RLA (DX)	RLA (CHW)	MCA	MFS	RLA (DX)	RLA (CHW)	MCA	MFS
380-415V/ 3Ph/ 50Hz	14.0	10.2	15	20	17.3	11.3	19	25	32.5	22.1	35	50	40.1	24.0	44	60	59.2	34.8	62	80	61.7	34.4	66	90
380V/ 3Ph/ 60Hz	14.0	10.2	15	20	17.3	11.3	19	25	32.5	22.1	35	50	40.1	24.0	44	60	59.1	34.8	62	80	62.2	34.4	84	80
460V/ 3Ph/ 60Hz	12.4	8.6	13	20	15.7	9.7	17	25	29.3	18.9	32	45	36.9	20.8	41	60	53.7	30.1	56	70	55.9	29.7	60	80

Model	DBDD/U 19				DBDD/U 22				DBDD/U 26				DBDD/U 29				DBDD/U 32			
	RLA (DX)	RLA (CHW)	MCA	MFS	RLA (DX)	RLA (CHW)	MCA	MFS	RLA (DX)	RLA (CHW)	MCA	MFS	RLA (DX)	RLA (CHW)	MCA	MFS	RLA (DX)	RLA (CHW)	MCA	MFS
380-415V/ 3Ph/ 50Hz	68.9	37.6	73	90	73.8	37.8	79	100	77.8	40.0	83	110	89.5	53.3	115	150	107.5	53.3	115	150
380V/ 3Ph/ 60Hz	67.4	37.6	71	80	76.2	37.8	82	100	81.2	40.0	87	110	94.0	41.8	102	150	106.7	53.3	114	150
460V/ 3Ph/ 60Hz	61.2	32.8	65	80	69.8	33.1	75	100	74.7	35.2	81	110	81.1	37.1	88	125	97.2	47.0	105	150

2.) STANDARD WITH OPTIONAL HUMIDIFIER

At 35°C (95°F) ambient; Return Air at 24°C/17°C/50 %RH (75°F/62.5°F/ 50 %RH)

Model	DBDD/U 03				DBDD/U 05				DBDD/U 09				DBDD/U 11				DBDD/U 14				DBDD/U 16			
	RLA (DX)	RLA (CHW)	MCA	MFS	RLA (DX)	RLA (CHW)	MCA	MFS	RLA (DX)	RLA (CHW)	MCA	MFS	RLA (DX)	RLA (CHW)	MCA	MFS	RLA (DX)	RLA (CHW)	MCA	MFS	RLA (DX)	RLA (CHW)	MCA	MFS
380-415V/ 3Ph/ 50Hz	23.1	19.3	24	30	26.4	20.4	28	35	41.6	31.2	44	60	49.2	33.1	53	70	76.4	52.0	79	90	78.9	51.6	83	100
380V/ 3Ph/ 60Hz	23.1	19.3	24	30	26.4	20.4	28	35	41.6	31.2	44	60	49.2	33.1	53	70	76.3	52.0	79	90	79.4	51.6	84	100
460V/ 3Ph/ 60Hz	19.9	16.1	21	30	23.2	17.3	25	35	36.9	26.4	40	50	44.4	28.4	49	70	67.9	44.2	71	90	70.0	43.9	74	100

Model	DBDD/U 19				DBDD/U 22				DBDD/U 26				DBDD/U 29				DBDD/U 32			
	RLA (DX)	RLA (CHW)	MCA	MFS	RLA (DX)	RLA (CHW)	MCA	MFS	RLA (DX)	RLA (CHW)	MCA	MFS	RLA (DX)	RLA (CHW)	MCA	MFS	RLA (DX)	RLA (CHW)	MCA	MFS
380-415V/ 3Ph/ 50Hz	86.1	54.8	90	110	91.0	55.0	96	125	95.0	57.1	101	125	106.7	59.0	114	150	124.6	70.5	132	175
380V/ 3Ph/ 60Hz	84.6	54.8	88	100	93.4	55.0	99	110	98.4	57.1	104	125	111.1	59.0	119	150	123.8	70.5	132	150
460V/ 3Ph/ 60Hz	75.4	47.0	79	100	83.9	47.3	89	110	88.9	49.4	95	125	95.3	51.2	102	150	111.4	61.1	119	150

Note : RLA - Rated Load Amps

MCA - Minimum Circuit Amps

MFS - Maximum Fuse Size

3.) COOLING & HOT GAS REHEAT

At 35°C (95°F) ambient; Return Air at 24°C/17°C/50 %RH (75°F/62.5°F/ 50 %RH)

Model	DBRD/U 03			DBRD/U 05			DBRD/U 09			DBRD/U 11			DBRD/U 14			DBRD/U 16		
	RLA	MCA	MFS	RLA	MCA	MFS	RLA	MCA	MFS	RLA	MCA	MFS	RLA	MCA	MFS	RLA	MCA	MFS
380-415V/ 3Ph/ 50Hz	5.0	6	15	7.7	9	20	14.3	17	30	20.1	24	45	31.9	35	50	33.6	38	60
380V/ 3Ph/ 60Hz	5.0	6	15	7.7	9	20	14.3	17	30	20.1	24	45	31.8	35	50	34.1	38	60
460V/ 3Ph/ 60Hz	5.0	6	15	7.7	9	20	14.3	17	30	20.1	24	45	31.1	34	45	32.5	37	60

Model	DBRD/U 19			DBRD/U 22			DBRD/U 26			DBRD/U 29			DBRD/U 32		
	RLA	MCA	MFS	RLA	MCA	MFS	RLA	MCA	MFS	RLA	MCA	MFS	RLA	MCA	MFS
380-415V/ 3Ph/ 50Hz	37.9	42	60	42.6	48	70	48.9	55	80	62.2	73	110	65.9	73	110
380V/ 3Ph/ 60Hz	36.4	40	60	45.0	50	70	52.3	58	80	66.6	74	110	65.1	73	110
460V/ 3Ph/ 60Hz	35.0	39	60	43.3	49	70	50.6	57	80	58.5	65	100	62.0	70	110

4.) COOLING & HOT GAS REHEAT WITH OPTIONAL HUMIDIFIER

At 35°C (95°F) ambient; Return Air at 24°C/17°C/50 %RH (75°F/62.5°F/ 50 %RH)

Model	DBRD/U 03			DBRD/U 05			DBRD/U 09			DBRD/U 11			DBRD/U 14			DBRD/U 16		
	RLA	MCA	MFS	RLA	MCA	MFS	RLA	MCA	MFS	RLA	MCA	MFS	RLA	MCA	MFS	RLA	MCA	MFS
380-415V/ 3Ph/ 50Hz	14.1	15	20	16.8	18	25	23.4	26	40	29.2	33	50	49.1	52	70	50.8	55	80
380V/ 3Ph/ 60Hz	14.1	15	20	16.8	18	25	23.4	26	40	29.2	33	50	49.0	52	70	51.2	56	80
460V/ 3Ph/ 60Hz	12.6	14	15	15.2	17	25	21.8	24	35	27.6	32	50	45.3	48	60	46.7	51	80

Model	DBRD/U 19			DBRD/U 22			DBRD/U 26			DBRD/U 29			DBRD/U 32		
	RLA	MCA	MFS	RLA	MCA	MFS	RLA	MCA	MFS	RLA	MCA	MFS	RLA	MCA	MFS
380-415V/ 3Ph/ 50Hz	55.1	59	80	59.7	65	90	66.0	72	100	79.3	87	125	83.0	90	125
380V/ 3Ph/ 60Hz	53.6	57	80	62.1	67	90	69.4	75	100	83.8	92	125	82.2	90	125
460V/ 3Ph/ 60Hz	49.2	53	80	57.5	63	90	64.7	71	100	72.7	80	110	76.2	84	125

Note : RLA - Rated Load Amps

MCA - Minimum Circuit Amps

MFS - Maximum Fuse Size

DIMENSIONAL AND WEIGHT DATA

UPFLOW

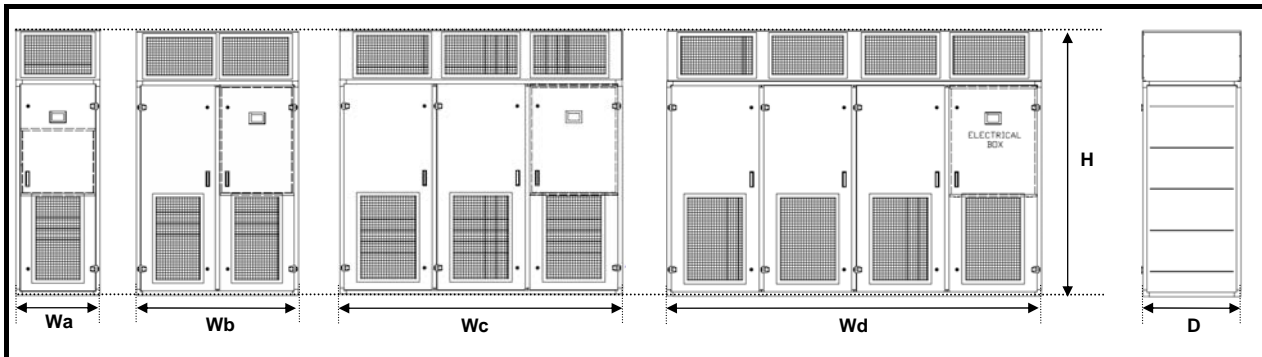

Model								Height	Depth	Width			
DX System	Weight kg (lbs.)	CW System	Weight kg (lbs.)	Dual Coils System	Weight kg (lbs.)	DX with Hot Gas Reheat	Weight kg (lbs.)	H mm (inch)	D mm (inch)	Wa mm (inch)	Wb mm (inch)	Wc mm (inch)	Wd mm (inch)
DBAU03	278 (612)	DBC03	246 (541)	DBDU03	303 (667)	DBRU03	292 (643)	2401 (95)	874 (34.4)	749 (29.5)			
DBAU05	282 (621)	DBC05	263 (579)	DBDU05	314 (692)	DBRU05	296 (652)	2401 (95)	874 (34.4)	749 (29.5)			
DBAU09	472 (1039)	DBC09	461 (1016)	DBDU09	535 (1180)	DBRU09	494 (1089)	2401 (95)	874 (34.4)		1464 (57.6)		
DBAU11	495 (1091)	DBC11	468 (1032)	DBDU11	558 (1230)	DBRU11	517 (1139)	2401 (95)	874 (34.4)		1464 (57.6)		
DBAU14	791 (1742)	DBC14	701 (1544)	DBDU14	886 (1953)	DBRU14	832 (1832)	2401 (95)	874 (34.4)			2554 (100.6)	
DBAU16	837 (1845)	DBC16	735 (1619)	DBDU16	932 (2056)	DBRU16	878 (1935)	2401 (95)	874 (34.4)			2554 (100.6)	
DBAU19	836 (1843)	DBC19	756 (1666)	DBDU19	957 (2109)	DBRU19	877 (1934)	2401 (95)	874 (34.4)			2554 (100.6)	
DBAU22	865 (1908)	DBC22	769 (1694)	DBDU22	986 (2174)	DBRU22	906 (1998)	2401 (95)	874 (34.4)			2554 (100.6)	
DBAU26	920 (2027)	DBC26	820 (1807)	DBDU26	1042(2297)	DBRU26	961 (2118)	2401 (95)	874 (34.4)			2554 (100.6)	
DBAU29	1180(2599)	DBC29	1056(2328)	DBDU29	1298(2859)	DBRU29	1221(2689)	2401 (95)	874 (34.4)				3394 (133.6)
DBAU32	1222(2693)	DBC32	1097(2418)	DBDU32	1340(2953)	DBRU32	1263(2783)	2401 (95)	874 (34.4)				3394 (133.6)

DOWNFLOW

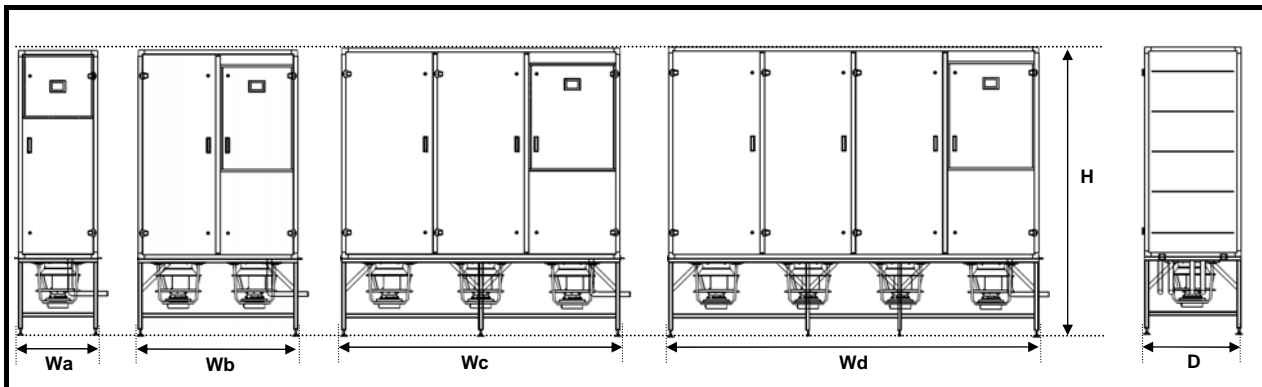

Model								Height	Depth	Width			
DX System	Weight kg (lbs.)	CW System	Weight kg (lbs.)	Dual Coils System	Weight kg (lbs.)	DX with Hot Gas Reheat	Weight kg (lbs.)	H mm (inch)	D mm (inch)	Wa mm (inch)	Wb mm (inch)	Wc mm (inch)	Wd mm (inch)
DBAD03	258 (570)	DBC03	226 (499)	DBDD03	283 (625)	DBRD03	272 (601)	2666 (105)	874 (34.4)	749 (29.5)			
DBAD05	262 (579)	DBC05	243 (536)	DBDD05	294 (649)	DBRD05	276 (610)	2666 (105)	874 (34.4)	749 (29.5)			
DBAD09	441 (972)	DBC09	430 (948)	DBDD09	504 (1111)	DBRD09	463 (1021)	2666 (105)	874 (34.4)		1464 (57.6)		
DBAD11	464 (1023)	DBC11	437 (964)	DBDD11	527 (1162)	DBRD11	486 (1072)	2666 (105)	874 (34.4)		1464 (57.6)		
DBAD14	743 (1636)	DBC14	653 (1438)	DBDD14	838 (1847)	DBRD14	784 (1726)	2666 (105)	874 (34.4)			2554 (100.6)	
DBAD16	789 (1739)	DBC16	687 (1513)	DBDD16	884 (1950)	DBRD16	830 (1829)	2666 (105)	874 (34.4)			2554 (100.6)	
DBAD19	788 (1738)	DBC19	708 (1560)	DBDD19	909 (2003)	DBRD19	829 (1828)	2666 (105)	874 (34.4)			2554 (100.6)	
DBAD22	817 (1802)	DBC22	721 (1588)	DBDD22	938 (2068)	DBRD22	858 (1892)	2666 (105)	874 (34.4)			2554 (100.6)	
DBAD26	872 (1922)	DBC26	772 (1701)	DBDD26	994 (2191)	DBRD26	913 (2012)	2666 (105)	874 (34.4)			2554 (100.6)	
DBAD29	1113(2453)	DBC29	990(2182)	DBDD29	1231(2713)	DBRD29	1154(2543)	2666 (105)	874 (34.4)				3394 (133.6)
DBAD32	1155(2547)	DBC32	1031(2272)	DBDD32	1273(2807)	DBRD32	1196(2637)	2666 (105)	874 (34.4)				3394 (133.6)

**Model 16-22 is with 2 fans, model 26 is with 3 fans (Diagram only shows 3 fans)

REMOTE AIR-COOLED CONDENSERS

TECHNICAL DATA

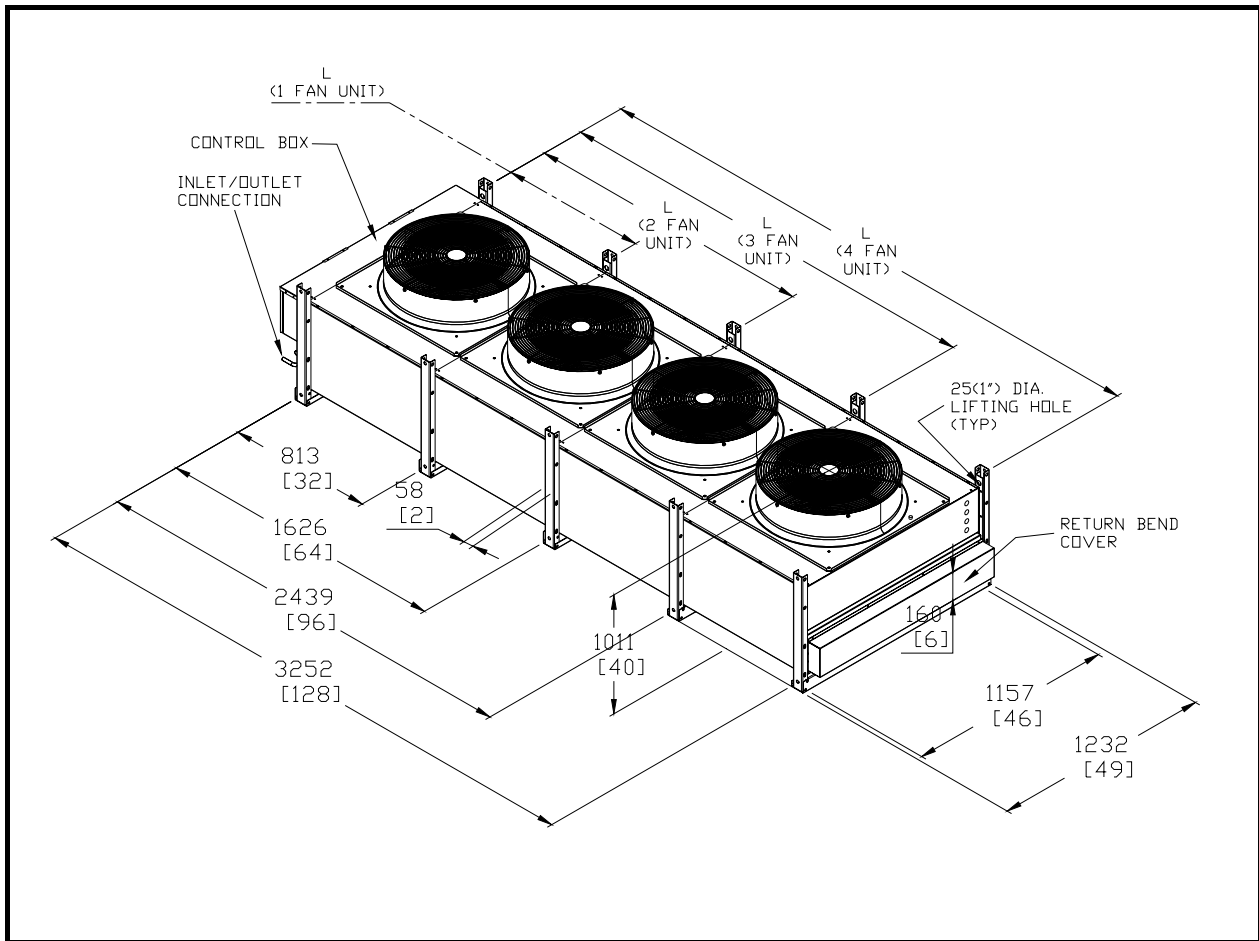

Model	Physical Data				Electrical Data							
	Length 'L' mm (inches)	Fans		Approx. Weight kg (lbs)	Motor Qty	RPM		Motor FLA (3-Phase)				
		Qty	Total L/S (CFM)			50Hz	60Hz	380V 50Hz	400V 50Hz	415V 50Hz	460V 60Hz	208V-230V 60Hz
DBRC 04	870 (34¼)	1	3210 (6800)	100 (220)	1	925	1110	2	1.9	1.8	2.7	5.5
DBRC 06	870 (34¼)	1	3210 (6800)	111 (244)	1	925	1110	2	1.9	1.8	2.7	5.5
DBRC 08	870 (34¼)	1	3210 (6800)	122 (268)	1	925	1110	2	1.9	1.8	2.7	5.5
DBRC 10	870 (34¼)	1	3210 (6800)	134 (295)	1	925	1110	2	1.9	1.8	2.7	5.5
DBRC 11	870 (34¼)	1	3210 (6800)	180 (400)	1	925	1110	2	1.9	1.8	2.7	5.5
DBRC 13	1683 (66¼)	2	6420 (13600)	190 (420)	2	925	1110	4	3.8	3.6	5.4	11
DBRC 17	1683 (66¼)	2	6420 (13600)	204 (450)	2	925	1110	4	3.8	3.6	5.4	11
DBRC 20	1683 (66¼)	2	6420 (13600)	265 (583)	2	925	1110	4	3.8	3.6	5.4	11
DBRC 26	2500 (98¼)	3	9630 (20400)	288 (634)	3	925	1110	6	5.7	5.4	8.1	16.5
DBRC 30	2500 (98¼)	3	9630 (20400)	320 (700)	3	925	1110	6	5.7	5.4	8.1	16.5
DBRC 34	2500 (98¼)	3	9630 (20400)	355 (780)	3	925	1110	6	5.7	5.4	8.1	16.5
DBRC 40	3308 (130¼)	4	12838 (27200)	380 (835)	4	925	1110	8	7.6	7.2	10.8	22
DBRC 44	3308 (130¼)	4	12838 (27200)	410 (900)	4	925	1110	8	7.6	7.2	10.8	22

Note: All dimensions are in mm (inches).

GUIDE SPECIFICATIONS

This specification describes requirements for precision air conditioning system. The system shall be designed to maintain precised temperature and humidity conditions for applications such as computer server rooms, telecommunication facilities, clean rooms, laboratories, etc. The precision environmental control system shall be factory assembled by Dunham-Bush Industries, Malaysia.

DESIGN REQUIREMENTS

(A) Direct Expansion (DX) System

- The system shall have a total cooling capacity of ____ MBH / ____ kW and a sensible cooling capacity of ____ MBH / ____ kW based on an entering air temperature of ____ °F / ____ °C DB and ____ °F / ____ °C WB.
- The system shall be designed based on ____ °F / ____ °C DB ambient temperature. For low ambient application, the system shall also be designed to operate at ____ °F / ____ °C DB ambient temperature.
- The unit shall be supplied with ____ / ____ / ____ (Volt/Phase/Hz) electrical service.
- The unit shall be of Upflow / Downflow configured model.

(B) Chilled Water (CW) System

- The system shall have a total cooling capacity of ____ MBH / ____ kW and a sensible cooling capacity of ____ MBH / ____ kW based on an entering air temperature of ____ °F / ____ °C DB and ____ °F / ____ °C WB.
- The system shall be supplied with chilled water with an entering water temperature of ____ °F / ____ °C and leaving water temperature ____ °F / ____ °C.
- The unit shall be supplied with ____ / ____ / ____ (Volt/Phase/Hz) electrical service.
- The unit shall be of Upflow / Downflow configured model.

(C) Dual Coils (DX + CW) System

- The system shall have a total cooling capacity of ____ MBH / ____ kW and a sensible cooling capacity of ____ MBH / ____ kW based on an entering air temperature of ____ °F / ____ °C DB and ____ °F / ____ °C WB.
- The DX system shall be designed based on ____ °F / ____ °C DB ambient temperature. For low ambient application, the system shall also be designed to operate at ____ °F / ____ °C DB ambient temperature.
- The CW system shall be supplied with chilled water with an entering water temperature of ____ °F / ____ °C and leaving water temperature ____ °F / ____ °C.
- The unit shall be supplied with ____ / ____ / ____ (Volt/Phase/Hz) electrical service.
- The unit shall be of Upflow / Downflow configured model.

(D) Direct Expansion (DX) System with hot gas reheat

- The system shall have a total cooling capacity of ____ MBH / ____ kW and a sensible cooling capacity of ____ MBH / ____ kW based on an entering air temperature of ____ °F / ____ °C DB and ____ °F / ____ °C WB.
- The system shall be designed based on ____ °F / ____ °C DB ambient temperature. For low ambient application, the system shall also be designed to operate at ____ °F / ____ °C DB ambient temperature.
- The unit shall be supplied with ____ / ____ / ____ (Volt/Phase/Hz) electrical service.
- The unit shall be of Upflow / Downflow configured model.

1 STANDARD FEATURES (ALL SYSTEMS, INDOOR UNIT)

1.1 Cabinet

The cabinet comprises an anodized aluminium frame of epoxy powder coated black color paint with nylon corners and removable steel sheet panels. All panels shall be externally installed onto the cabinet by using special stopper system without using screws. The stopper system shall also facilitate the removable of panels for additional ease of field installation, service and maintenance on the system. All panels and access doors shall be fabricated from sturdy heavy gauge of 1.0mm steel sheets with epoxy powder coated oven baked black color paint to provide a durable finish. All panels shall be of 25mm (1 inch) thick single skin and lined with minimum 2lbs/ft³ density thermal and acoustical fiberglass insulation with fire resistant of Class O (BS 476 Part 6, 7). The system shall be designed for front access only with hinged and lock type full height doors.

1.2 Filters

The system shall be provided with 2 inches (50mm) deep (for model 03-05) or 4 inches (100mm) deep (for model 11-32) extended surface pleated disposable type filters rated for MERV8 efficiency to ASHRAE 52.2 standard (equivalent to EU4). Filters shall be withdrawable from the front of the unit.

1.3 Fan Motor

The system are equipped with EC Fan Motor set for both upflow & downflow model.

1.4 Evaporator Air Discharge

1.4.1 Up-Flow (Front Free Return)

The system shall be configured for up-flow pattern with front free evaporator return air and top evaporator air discharge. The system shall be supplied with grilles on the cabinet doors for front return air configuration. Up-flow systems are equipped with Discharge Plenum.

1.4.2 Down-Flow (Top Free or Ducted Return)

The system shall be configured for down-flow pattern with top free or ducted evaporator return air and bottom evaporator air discharge through the raised floor.

GUIDE SPECIFICATIONS

1.5 Electric Reheat or Hot Gas Reheat

1.5.1 For Direct Expansion (DX) System, Chilled Water (CW) System and Dual Coils (DX+CW) System only.

The electric reheat shall be factory installed low watt density finned-tubular nickel plated element heater with overheat safety controls. The electric reheat shall be of three equal stages giving a more accurate controlled response to the room requirement.

1.5.2 For Direct Expansion (DX) System with Hot Gas Reheat only

The unit shall incorporate a hot gas reheat coil located downstream of the evaporator coil with modulating valve which is completely integrated to the unit's microprocessor control. For units with two refrigerant circuits, each circuit shall operate independently with its own modulating valve.

1.6 Electrical Circuits

The system shall be provided with a factory installed electrical enclosure as per local code requirements. Control voltage of the system shall be 24Vac. The fan motor(s), compressor(s), electric heaters, humidifier (if applicable) shall have their own circuit breaker and contactor. The electrical circuit shall have provision for user to cut off control power during fire / emergency shutdown

1.7 Control System – Vision 2020i Controller

1.7.1 Controller and display

The unit shall be provided with Vision 2020i control system with the following features,

- The control algorithm and parameters shall be stored in flash memory and E²PROM of the controller and shall retain even in the event of power failures, without requiring a backup battery
- 4.3" graphical touch terminal with 65k color display
- Built in memory for data logging
- Temperature and humidity controlled
- Configurable by user
- Alarm status/display
- Analog input/output display
- Digital input/output status
- Remote start/stop input
- Digital input for customer input alarm
- General alarm output (dry contact)
- Self-diagnostics
- Security password access with multiple access level for advanced settings
- Unit status display with following information:
 - Current room temperature and temperature setpoint
 - Current room relative humidity and relative humidity setpoint
 - System ON/OFF
 - Operating mode (cooling/ heating/ humidifying/ dehumidifying)

1.7.2 Alarm Monitoring

When the system is in alarm condition, the system shall activate an audible buzzer and

visual alarm message on the terminal display. A digital output (dry contact) shall be closed to indicate the alarm condition. The following alarm conditions shall be monitored by the controller:

- High room temperature
- Low room temperature
- High supply air temperature
- High room humidity
- Low room humidity
- No air flow/loss of air flow
- Filter dirty
- Sensor failure
- Evaporator fan overload alarm
- Customer interlock alarm
- Unit/ Compressor running hours threshold exceeded
- LAN network disconnected alarm
- High/Low refrigerant pressure alarm (DX models)
- Chilled water flow switch alarm (chilled water models)
- Humidity Alarms
- Under floor water detector alarm (optional)
- Smoke detector alarm (optional)

1.7.3 Master-Slave Sequencing Control

When more than one unit is present in the system, master-slave or duty-standby control of this group of units shall be done by just connecting controller of each unit in serial and require no additional controller.

1.7.4 BMS communications and remote monitoring

ModBus RTU RS485 communication port shall be a standard feature of the controller. On top of that, the following options shall be available for BMS communications and remote monitoring:

- ModBus TCP/IP
- BACnet TCP/IP / PTP / MSTP
- LONworks
- GSM Modem
- SNMP

2 DIRECT EXPANSION (DX) SPLIT SYSTEMS WITH REMOTE OUTDOOR AIR COOLED CONDENSER (DBRC MODELS)

2.1 Compressor

Compressor shall be mounted on the base via vibration isolators. Compressor shall be charged with polyolester oil and designed for use with R410A refrigerant.

2.2 Refrigeration Circuits

The refrigeration system shall be of the direct expansion type with one (Model 03-11) or two (Model 16-32) hermetic scroll compressors complete with rotalock connections. All refrigeration circuit shall be pre-piped with copper tubing and include expansion valve with external equalizer, filter dryer, sight glass, refrigerant service valves, pressure fittings of manual reset high pressure control/auto reset low pressure safety cutouts and charging/access ports in each circuit.

GUIDE SPECIFICATIONS

2.3 Evaporator Coil

The evaporator coil shall be of draw through air design for uniform air distribution. The evaporator coil shall be quality construction of seamless copper tube, mechanically bonded to hydrophilic aluminium fins with galvanized coil plates. The coil shall be factory leak and pressure tested to 650psig (45 bar) for R410A system and the refrigeration system shall be sealed prior to shipment. A galvanized and painted drain pan shall be provided to cover the entire coil area. The drain pan shall be designed to incorporate sloped gutter for complete condensate removal.

2.4 Remote Outdoor Air Cooled Condenser (DBRC Models)

The remote condenser shall be constructed from sturdy heavy gauge steel sheets with epoxy powder coated oven baked, factory standard beige color to provide a durable finish.

The remote condenser shall include direct driven propeller fans, condenser coil, fan guard, thermally protected rated IP55 motors, integral factory wired and tested control panel. The condenser coil shall be quality construction of seamless copper tube, mechanically bonded to aluminium fins with galvanized coil plates. The coil shall be factory leak and pressure tested to 650psig (45 bar) for R410A system and the refrigeration system shall be sealed prior to shipment.

The evaporator and condenser sections shall ship with a dry-nitrogen holding charge ready for field refrigerant charging.

3 CHILLED WATER (CW) SYSTEMS

3.1 Chilled Water Coil

The evaporator coil shall be of draw through air design for uniform air distribution. The chilled water coil shall be quality construction of seamless copper tube, mechanically bonded to hydrophilic aluminium fins with galvanized coil plates. The coil shall be factory leak and pressure tested to 450psig (31 bar) and sealed prior to shipment. Copper pipe for brazed connection shall be provided as standard. A galvanized and painted drain pan shall be provided to cover the entire coil area. The drain pan shall be designed to incorporate sloped gutter for complete condensate removal.

3.2 Chilled Water Control

The water circuit shall include 3-way forged brass valve and modulating actuators. The microprocessor positions the valve in response to room condition. Cooling capacity shall be controlled by bypassing chilled water around the coil.

4 OPTIONS

4.1 Stainless Steel Drain Pan

A stainless steel condensate drain pan shall be provided for the evaporator/chilled water coil in lieu of standard galvanized and painted drain pan.

4.2 Discharge Plenum (Up-flow Units only)

A discharge plenum box shall be provided for field installation on the top of the up-flow unit. The plenum

box shall be 18 inches (457mm) high, insulated and painted to match the color of the indoor unit. The plenum box shall be fitted with double deflection grilles for room discharge of conditioned air.

4.3 Steam Generating Humidifier

Humidifier shall be factory installed inside the unit. The humidification system shall be an electrode cylinder type, complete with fill valve, drain valve, adjustable humidity output and automatic flush cycle activated on demand from the microprocessor control system.

4.4 Hot Gas Bypass (DX Systems only)

The refrigerant circuit(s) shall be provided with a hot gas bypass system for evaporator freeze-protection and capacity modulation during low load conditions.

4.5 Liquid Line Solenoid Valve (DX Systems only)

A factory fitted liquid line solenoid valve shall be provided for each refrigeration circuit as an option.

4.6 Double Skin Panels

All panels shall be provided with galvanized internal skin.

4.7 Insulflex Closed Cell Insulation

All panels shall be single skin and lined with Insulflex Closed Celled insulation (in lieu of fiberglass insulation) with fire resistant of Class O (BS476 Part 6) and Class 1 (BS476 Part 7).

4.8 Hydrophilic or Copper Fin for Condenser Coil (DBRC)

Condenser coils shall be provided with hydrophilic or copper fins in lieu of aluminium.

4.9 Black Color Epoxy Powder Coating for Remote Condenser (DBRC)

The remote condenser DBRC shall be epoxy powder coated oven baked black color paint in lieu of standard beige color.

4.10 Under Floor Water Detector

A remote water leak detector shall be factory provided for field installation. When water leak is detected, cooling mode of the unit is off.

4.11 Smoke Detector

A smoke detector shall be supplied loose for remote mounting. The unit shall shut down when smoke alarm is triggered.

4.12 BMS communication cards

BMS communication card shall be factory installed to enable high level interfacing with BMS system. ModBus, BACnet, LONworks, SNMP communication protocols shall be available as option.

4.13 Low Ambient Kit

Fan cycling for better performance during low ambient.



Malaysia

Lot 5755-6,
Kidamai Industrial Park,
Bukit Angkat,
43000 Kajang,
Selangor, Malaysia

Tel: +603-8924 9000
Fax: +603-8739 5020

China

No. 1 Dunham-Bush Road,
Laishan District,
Yantai,
Shandong Province,
China 264003

Tel: +86-535-739 7888
Fax: +86-535-739 7999

United Kingdom

8 Downley Road,
Havant,
Hampshire,
England PO9 2JD

Tel : +44-23-9247 7700
Fax: +44-23-9245 0396

United States of America

11948 Miramar Parkway
Miramar, Florida 33025
United States of America

Tel: +305-883 0655
Fax: +305-883 4467

United Arab Emirates

Office # 2606,
Fortune Executive Towers,
Cluster T1, Jumeirah Lake Tower
Dubai, UAE

Tel: +971-4-443 9207
Fax: +971-4-443 9208

South Africa

No. 57 Sovereign Drive
Route 21 Corporate Park
Irene, Pretoria
South Africa

Tel: +27-12-345 4202
Fax: +27-12-345 4203

India

957D, 9th Floor, Tower B-1,
Spaze i-Tech Park, Sohna Road,
Sector-49, Gurugram,
Haryana-122018, India

Tel: +91-124-414 4430

Indonesia

The Vida Building 7th Floor
Jl. Raya Perjuangan
No. 8 Kebon Jeruk
Jakarta 11530, Indonesia

Tel: +62-21-2977 8100
Fax: +62-21-2977 8001

Thailand

1 QHouse Lumpini,
27th Floor, South Sathorn Road,
Tungmahamek, Sathorn,
Bangkok Thailand 10120

Tel: +66-0-2610 3749
Fax: +66-0-2610 3601

Singapore

2 Kallang Pudding Road
#07-07 Mactech Building
Singapore 349307

Tel: +65-6842 2012
Fax: +65-6842 2013

Vietnam

10th Floor, Nam A Bank Tower,
201-203 Cach Mang Thang 8 Street,
District 3, Ho Chi Minh City,
Vietnam

Tel: +84-8-6290 3108
Fax: +84-8-6290 3109

DUNHAM-BUSH®

info@dunham-bush.com
www.dunham-bush.com



Products that perform...By people who care

Manufacturer reserves the right to change specifications without prior notice.

M-S-0706A-0719